

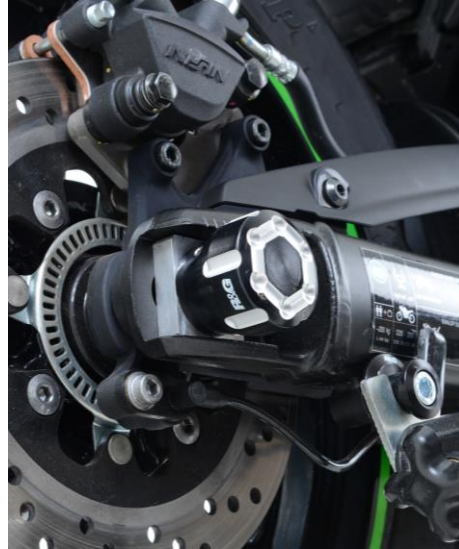

FITTING INSTRUCTIONS FOR SP0069MC SWINGARM PROTECTORS
KAWASAKI VULCAN S '15-



THIS KIT CONTAINS THE ITEMS PICTURED AND LABELLED BELOW.
DO NOT PROCEED UNTIL YOU ARE SURE ALL PARTS ARE PRESENT.

Please note that the way the kit is packed does not necessarily represent the way of mounting to the bike.

Please note that in cases where kits are packed with a plastic tube separating components on the spindle bar (this tube should be discarded).

THE PARTS SHOWN MAY BE REPRESENTATIVE ONLY (FOR CLARITY OF INSTRUCTIONS ONLY).

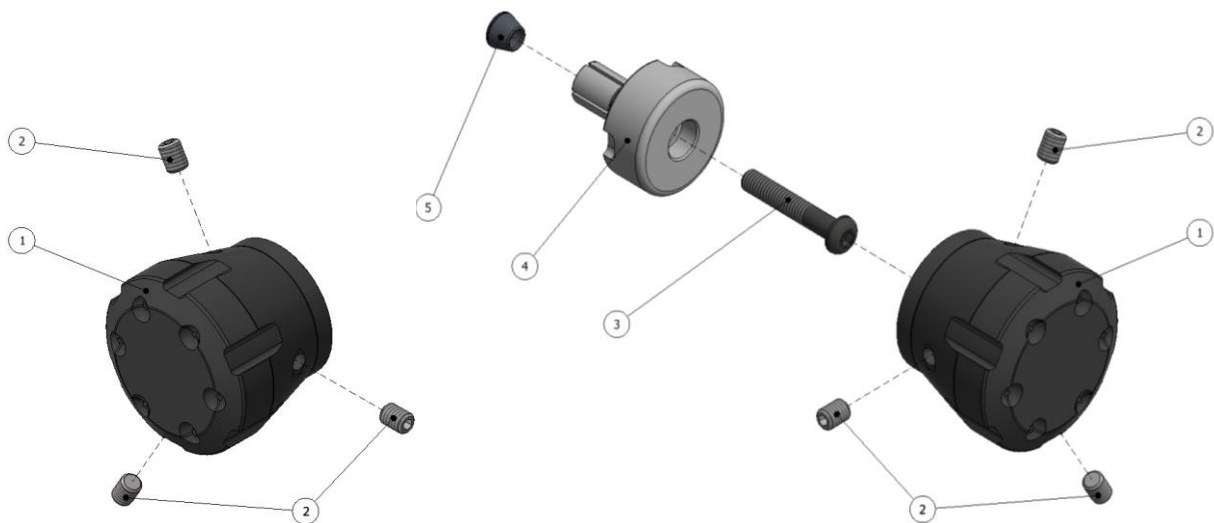

Left Side

Right Side



LEGEND

- ITEM 1 = BOBBIN (BM0002) (x2).
ITEM 2 = M6 x 8mm LONG GRUB SCREW (x6).
ITEM 3 = M6 x 35mm LONG BUTTON HEAD BOLT (x1).
ITEM 4 = EXPANDER (M0457) (x1).
ITEM 5 = TAPERED NUT (H0052) (x1).

TOOLS REQUIRED

- 3 & 4mm Allen key.

FITTING INSTRUCTIONS

To fit the Left Side

- Fit the three M6 x 8mm long grub screws (item 2) into the three threaded holes on either bobbin (item 1 – BM0002), ensuring they protrude no further than the internal bore of the bobbin.
- Place the bobbin over the exposed nut and split pin so the bobbin sits against the chain adjuster block, before tightening the three grub screws equally to clamp up on the flats of the spindle nut.

To fit the Right Side

- Fit the three M6 x 8mm long grub screws (item 2) into the three threaded holes on either bobbin (item 1 – BM0002), ensuring they protrude no further than the internal bore of the bobbin.
- Assemble the expander (item 4 – M0457) along with the M6 x 35mm long button head bolt (item 3) and tapered nut (item 5 – H0052) as shown on page one, and tighten the bolt so that the tapered nut just starts to expand the expander.
- Fit this assembly into the centre hole of the rear wheel spindle on the right side of the bike, before tightening the bolt to secure the expander in place.
- Place the bobbin over the expander so the grub screws roughly align with the machined pockets on the expander, before tightening the three grub screws equally to clamp up on the expander.

- Ensure both swingarm protectors are correctly fitted
- Please check regularly to ensure tightness.

ISSUE 1 01/03/2016 (AR)

CONSUMER NOTICE

The catalogue description and any exhibition of samples are only broad indications of the Products and R&G may make design changes which do not diminish their performance or visual appeal and supplying them in such state shall conform to the order. The Buyer acknowledges no representation or warranty (other than as to title) has been given or will apply to the Products other than those in R&G's order or confirmation and the Buyer confirms it has chosen the Products as being of merchantable quality and suitable for its particular purposes. Where R&G fits the Products or undertakes other services it shall exercise reasonable skill and care and rectify any fault free of charge unless the workmanship has been disturbed. The Buyer is responsible for ensuring that the warranty on the motorcycle is not affected by the fitting of the Products. On return of any defective Products R&G shall at its option either supply a replacement or refund the purchase money but shall not be liable if the Products have been modified or used or maintained otherwise than in accordance with R&G's or manufacturer's instructions and good engineering practice or if the defect arises from accident or neglect. Other than identified above and subject to R&G not limiting its liability for causing death and personal injury, it shall not be liable for indirect or consequential loss and otherwise its liability shall be limited to the amounts paid by the Buyer for the Products or the fitting or service concerned. These terms do not affect the Buyer's statutory rights.

R&G RACING RETURNS POLICY (NON-FAULTY GOODS)

Returns must be pre-authorized (if not pre-authorized the return will be rejected). Goods may only be returned direct to us if they were purchased direct from us (customer must prove if necessary). Otherwise to be returned to original vendor. Goods must be in resellable condition, in the opinion of R&G Racing. All returns are subject to a 25% restocking and handling fee (25% of the gross value exc. P&P – at the prevailing price at time of purchase). The customer must pay any and all carriage charges. No returns of discontinued products, unless within 14 days of purchase. This policy does not affect your statutory rights and does not refer to faulty goods.

R&G Racing

Unit 1, Shelley's Lane, East Worldham, Alton, Hampshire, GU34 3AQ

Tel: +44 (0)1420 89007 Fax: +44 (0)1420 87301 www.rg-racing.com Email: info@rg-racing.com



**NOTICE DE MONTAGE SP0069MC PROTECTIONS BRAS OSCILLANT
KAWASAKI VULCAN S '15-**

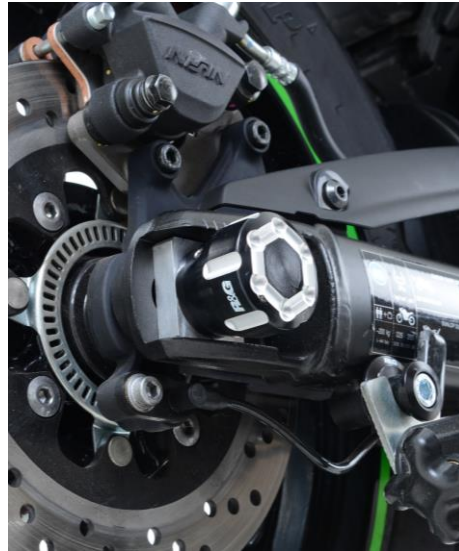

**LE KIT CONTIENT LES ARTICLES EXPOSES CI-DESSOUS, VERIFIER QUE TOUTES LES PIECES SOIENT
PRESENTEES AVANT DE PROCEDER AU MONTAGE.**

**LA FAÇON DONT LE KIT EST EMBALLE NE CORRESPOND PAS FORCEMENT A LA FAÇON DE MONTER LES
PIECES SUR LA MOTO.**

Notez que si les kits sont emballés avec un tube en plastique qui sépare les composants sur l'axe, ce tube doit être jeté.

LES PARTIES PRESENTEES PEUVENT ETRE UNIQUEMENT REPRESENTATIVES (POUR LA CLARTE DES INSTRUCTIONS UNIQUEMENT).

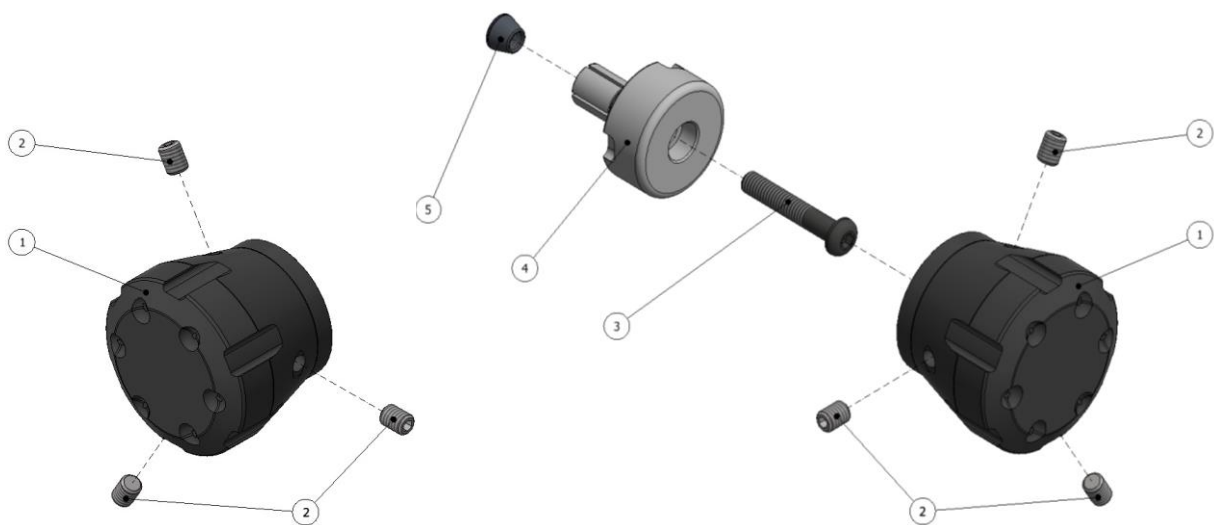

Coté gauche

Coté droit



LEGENDE

ARTICLE 1 = BOBINE (BM0002) (x2).

ARTICLE 2 = M6 x 8mm VIS (x6).

ARTICLE 3 = M6 x 35mm BOULON (x1).

ARTICLE 4 = EXPANDEUR (M0457) (x1).

ARTICLE 5 = ECROU CRANTE (H0052) (x1).

OUTILS REQUIS

- Clé Allen 3 & 4mm.

NOTICE DE MONTAGE

Installation coté gauche

- Insérer les 3 vis M6 x 8mm (article 2) dans les trous filetés de chaque bobine (article 1 – BM0002), en veillant à ce qu'ils ne dépassent pas plus que l'intérieur de la bobine.
- Placer la bobine autour de l'écrou et de la goupille de façon à ce que la bobine se place contre le bloc ajusteur de chaîne, avant de serrer les 3 vis de façon identique pour serrer sur les plats de l'écrou d'axe.

Installation coté droit

- Insérer les 3 vis M6 x 8mm (article 2) dans les trous filetés de chaque bobine (article 1 – BM0002), en veillant à ce qu'ils ne dépassent pas plus que l'intérieur de la bobine.
- Assembler l'expandeur (article 4 – M0457) avec le boulon M6 x 35mm (article 3) et l'écrou cranté (article 5 – H0052) voir page 1, et serrer le boulon de façon à ce que l'écrou commence à écarter l'expandeur.
- Installer cet ensemble dans le trou central du moyeu de roue arrière du coté droit de la moto, avant de serrer le boulon pour fixer l'expandeur en place.
- Placer la bobine autour de l'expandeur de façon à ce que les vis s'alignent avec les poches usinées sur l'expandeur, avant de serrer les 3 vis de façon égale pour serrer l'expandeur.
- Veiller à ce que les 2 protections soient correctement montées.
- Vérifier le serrage régulièrement pour vous assurer du serrage.

ISSUE 1 01/03/2016 (AR)

CONSUMER NOTICE

The catalogue description and any exhibition of samples are only broad indications of the Products and R&G may make design changes which do not diminish their performance or visual appeal and supplying them in such state shall conform to the order. The Buyer acknowledges no representation or warranty (other than as to title) has been given or will apply to the Products other than those in R&G's order or confirmation and the Buyer confirms it has chosen the Products as being of merchantable quality and suitable for its particular purposes. Where R&G fits the Products or undertakes other services it shall exercise reasonable skill and care and rectify any fault free of charge unless the workmanship has been disturbed. The Buyer is responsible for ensuring that the warranty on the motorcycle is not affected by the fitting of the Products. On return of any defective Products R&G shall at its option either supply a replacement or refund the purchase money but shall not be liable if the Products have been modified or used or maintained otherwise than in accordance with R&G's or manufacturer's instructions and good engineering practice or if the defect arises from accident or neglect. Other than identified above and subject to R&G not limiting its liability for causing death and personal injury, it shall not be liable for indirect or consequential loss and otherwise its liability shall be limited to the amounts paid by the Buyer for the Products or the fitting or service concerned. These terms do not affect the Buyer's statutory rights.

R&G RACING RETURNS POLICY (NON-FAULTY GOODS)

Returns must be pre-authorized (if not pre-authorized the return will be rejected). Goods may only be returned direct to us if they were purchased direct from us (customer must prove if necessary). Otherwise to be returned to original vendor. Goods must be in resellable condition, in the opinion of R&G Racing. All returns are subject to a 25% restocking and handling fee (25% of the gross value exc. P&P – at the prevailing price at time of purchase). The customer must pay any and all carriage charges. No returns of discontinued products, unless within 14 days of purchase. This policy does not affect your statutory rights and does not refer to faulty goods.

R&G Racing

Unit 1, Shelley's Lane, East Worldham, Alton, Hampshire, GU34 3AQ

Tel: +44 (0)1420 89007 Fax: +44 (0)1420 87301 www.rg-racing.com Email: info@rg-racing.com